MDU-G4
MECHANICAL DRIVE UNIT

INSTALLATION MANUAL

1 Components.....7

1.1 Supported Models7

1.2 MDU-G4 Main Hardware Kit7

1.3 MDU-G4 Switch Kit7

2 MDU-G4 Installation8

2.1 MDU-G4 Installation Overview8

2.2 MDU-G4 Installation Procedure8

2.2.1 *Install the Main Gear on the Steering Wheel* 8

2.2.2 *Attach the Anti-Rotation Pin* 11

2.2.3 *Install the MDU-G4* 12

3 Universal Bracket Installation13

3.1 Universal Bracket Installation13

3.1.1 *Universal Bracket Installation Kit Overview* 13

3.1.2 *Universal Bracket Installation Procedure* 14

4 Cable Harness Installation16

4.1 Overview16

4.1.1 *Safety Notes* 16

4.1.2 *Cable Harness Connections Overview* 16

4.2 Cable Harness Installation Procedure17

5 On/Off Switch18

5.1 Overview18

5.2 On/Off Switch18

5.3 Led Lights18

6 Care and Maintenance19

7 End-of-life disposal20

8 Guarantee terms20

INTRODUCTION

The MDU-G4 mechanical drive unit is a high performance steering actuator designed to provide high precision steering when coupled to a GPS automated steering system. The MDU-G4 was designed for ease of installation, portability between vehicles and a long service life. The MDU-G4 uses a reliable high torque DC motor and a robust and simple gear drive for fast and responsive steering under all field steering conditions. The unique split gear design and quick-release latch makes for an easy installation that does not require the removal of the steering wheel so you gain time and are also able to easily transfer your MDU-G4 between many

This manual provides the basic information and overview of the installation procedure for installing the MDU-G4 steering actuator on a vehicle. The MDU-G4 can be installed on many makes, models, and types of vehicles. Read this manual prior to beginning the installation as this manual provides the cautions and warnings that need to be recognized and understood prior to installing or operating an MDU-G4 system.

This manual provides the instructions for the installation of the components that come with this MDU-G4 installation kit. The installation is broken down into specific sections that may refer to sub-kit assemblies that are part of this kit. These sub-kits will come with their own instructions so refer to those when directed for information on installing the sub-kit parts.

Prior to operating and installing the MDU-G4 system, be sure to read and understand the *Steering Controller Operator's Manual* that comes with the Steering Controller system. That manual provides the instructions on how to operate the MDU-G4 system as well additional safety information.

LEGAL DISCLAIMER

NOTE:

READ AND FOLLOW ALL INSTRUCTIONS IN THIS MANUAL CAREFULLY BEFORE INSTALLING OR OPERATING THE MDU-G4 SYSTEM.

NOTE:

TAKE CAREFUL NOTE OF THE SAFETY INFORMATION IN THE SAFETY INFORMATION SECTION OF THIS MANUAL AND THE ADDITIONAL SAFETY MESSAGES PROVIDED THROUGHOUT THIS MANUAL AND ANY OTHER SUPPLEMENTAL MATERIAL PROVIDED.

The manufacturer disclaims any liability for damage or injury that results from the failure to follow the instructions, cautions, and warnings set forth herein.

Please take special note of the following warnings:

1. There is **NO** obstacle avoidance system included with the manufacturer's product. The owner must always have a human present in the operator's seat of the vehicle when the MDU-G4 system is in use to look for obstacles including people, animals, trees, ditches, buildings, etc. and take control of the vehicle to manually avoid them if necessary.
2. The MDU-G4 system does **NOT** control the speed of the vehicle. The operator must always adjust the speed of the vehicle manually so that it is operated at a safe speed that will not cause the vehicle to roll over or go out of control.
3. The MDU-G4 system will take over control of the vehicle's steering system when the MDU-G4 system is activated during: Testing, calibration, tuning, and automatic steering operations. The vehicle's steering axles, tracks, articulation point, or wheels may move unpredictably when activated. Prior to starting the vehicle and/or activating the MDU-G4 system, verify that all people and obstacles are clear of the vehicle to prevent death, injury, or damage to property.
4. Use of the MDU-G4 system is **NOT** permitted while the vehicle is on public roads or in public areas. Verify that the system is powered **OFF** before driving on roads or in public areas.

SAFETY INFORMATION**Safety Instructions**

Read these safety instructions and the user's instructions thoroughly, and follow the instructions.

- Only an operator who is fully authorized to drive the tractor can make use of the MDU-G4 GPS Assisted Steering System.
- The operator must not exceed the safe speed limit for the terrain it is operating on.
- An operator must always be conscious of his actions when operating the MDU-G4 GPS Assisted Steering System.
- When installing the MDU-G4 Assisted Steering System do not force the components as this can result in the components being damaged.
- Always follow the instructions in the installation; operation; and maintenance manual.
- Only an authorized party should install the MDU-G4 GPS Assisted Steering System.
- Always carry out an inventory of the components delivered to ensure all the correct components are present. Never use replacement components. Only use original components.
- If there are any questions regarding the safe operation of the MDU-G4 GPS Assisted Steering System or the instructions in the manuals do not hesitate to always contact the responsible expert.
- Always use the correct tools to install the MDU-G4 GPS Assisted Steering System.
- Caution must be taken when installing the MDU-G4 GPS Assisted Steering System to prevent injury.
- Do not use or operate the MDU-G4 GPS Assisted Steering System in unsafe weather conditions. Do not use or operate the MDU-G4 GPS Assisted Steering System if the terrain is unsafe.
- It is not allowed for an unauthorized person to use or operate the MDU-G4 GPS Assisted Steering System.
- Before starting work activities, the operator must have sufficient knowledge of procedures how operate the MDU-G4GPS Assisted Steering System in a safe manner.
- When installing the MDU-G4 GPS Assisted Steering System, all safety precautions must be taken into account and it should not be used if there are any parts loose, missing or damaged.
- Only an operator who has been trained or is experienced may operate the MDU-G4 GPS Assisted Steering System.
- Before using the MDU-G4 GPS Assisted Steering System all functions must be checked and controlled for their correct working order. When there is any doubt, do not take any risks always consult an expert.
- Before operating the MDU-G4 GPS Assisted Steering System, control all functions of the Presence Switch and confirm the settings to ensure it functions correctly.
- Turning the MDU-G4 GPS Assisted Steering System on and off must always happen consciously following the correct prescribed procedures.
- If an abnormal phenomenon presents itself, for example excessive vibrations noise, then immediately turn off the MDU-G4 GPS Assisted Steering System and consult a responsible expert.
- When the MDU-G4 GPS Assisted Steering System is being cleaned or when maintenance takes place, it must be totally turned off and free of any electrical currents.
- The operator of the MDU-G4 GPS Assisted Steering System must have complete knowledge about how to react in case of emergency.
- A trained expert must always carry out maintenance or repairs on the MDU-G4 GPS Assisted Steering System.
- During repair or replacement of components on the MDU-G4 GPS Assisted Steering System only original components must be used.
- Always wear correct prescribed personal protection equipment during the use or cleaning or maintenance of the MDU-G4 GPS Assisted Steering System.
- Always use the recommended cleaning materials and accessories when the MDU-G4 GPS Assisted Steering System is cleaned.
- Every unsafe condition or situation on the MDU-G4 GPS Assisted Steering System must be reported to the responsible persons.
- Do not leave or place objects on or in the area of the MDU-G4 GPS Assisted Steering System.













Warning Alerts

The MDU-G4 system installer and manufacturer disclaim any responsibility for damage or physical harm caused by the failure to adhere to the following safety requirements:

- As the operator of the vehicle, you are responsible for its safe operation.
- The steering system is NOT designed to replace the vehicle's operator.











NOTE: AFTER THE INSTALLATION OF THE MDU-G4 SYSTEM, VERIFY THAT ALL THE SCREWS, BOLTS, NUTS, AND CABLE CONNECTIONS ARE TIGHT.

VERIFY THAT ALL THE CABLES HAVE BEEN SECURED TO PREVENT THEM FROM BEING DAMAGED.

	 WARNING
	To understand the potential hazards associated with the operation of a MDU-G4 equipped vehicle, read the provided documentation prior to installing or operating the MDU-G4 system.
	 WARNING
	To prevent accidental death or injury from being run over by the vehicle or automated motion of the steering system, never leave the vehicle's operator seat with the MDU-G4 system engaged.
	 WARNING
	Movement of the Electronic Control Unit (ECU) relative to the vehicle may cause erratic steering and sudden loss of vehicle control while in AutoSteer mode. Always keep the Electronic Control Unit (ECU) firmly secured to the vehicle. Do not operate your MDU-G4 system with a loose ECU.
	 WARNING
	To prevent accidental death or injury from being run over by the vehicle verify that area around the vehicle is clear of people and obstacles before startup, calibration, tuning, or use of the MDU-G4 system.
	 WARNING
	To prevent the accidental engagement of the MDU-G4 system and loss of vehicle control while driving on roads, turn the MDU-G4 power switch to the OFF position or remove the MDU-G4 from the steering column. Never drive on roads or in public areas with the MDU-G4 system powered up.
	 WARNING
	The MDU-G4 GPS Assisted Steering System is solely intended for agricultural use. The systems should only be used with agricultural vehicles and should not be used with any other type of vehicle or for any other purposes. Unapproved applications may result in loss of vehicle control resulting in injury or death.

Caution Alerts

The Steering system installer and manufacturer disclaim any responsibility for damage or physical harm caused by the failure to adhere to the following safety requirements:

	 CAUTION
	The MDU-G4 system does not detect obstacles in the vehicle's path. The vehicle operator must observe the path being driven and take over steering manually if an obstacle must be avoided.
	 CAUTION
	The MDU-G4 system does not control the speed of the vehicle. The operator must manually adjust the speed of the vehicle to keep the vehicle safely under control.
	 CAUTION
	To avoid possible damage to electronic circuits caused by electrostatic discharge, never touch the contacts on the ECU electrical connectors at any time.
	 CAUTION
	Make sure the assembly does not interfere with any of the vehicle control levers on the steering column.
	 CAUTION
	Make sure that the main gear race has properly engaged on the three rollers before closing latch. If the race is not engaged properly, you risk damaging the MDU-G4 and steering wheel while the MDU-G4 GPS Assisted Steering System is operating.

INSTALLATION REQUIREMENTS

Standard Tool Requirements

The installer is assumed to have a complete set of common installation tools including:

- 7/64" Allen
- Wrench 5/32"
- Allen Wrench 1/4"
- Open Wrench
- 1/4" Nut Driver
- Torque wrench 0 to 20 lbf-in (0 to 2 Nm), for 5/32" hex bit

Vehicle Requirements

Prior to installing the MDU-G4 system, verify the following items on the vehicle:

- The vehicle's steering system is in good working order. Drive the vehicle to verify this prior to beginning the installation. There should be no play in the steering and the vehicle should turn proportionally the same to the left and right.
- The vehicle's electrical system and battery must be in good working order.
- The vehicle should be fully cleaned before installing the MDU-G4 system. A clean vehicle will improve the overall installation and cable routing.

If any issues are discovered with the vehicle, they must be repaired prior to beginning the MDU-G4 installation by a qualified service person for the vehicle.

Note: this installation manual, vehicle specific installation manuals, and sub-kit manuals contains valuable information for servicing the mdu-g4 system. After the installation is complete, store all of these manuals in a safe place for future reference.

TECHNICAL SUPPORT

Refer to your Steering Controller Operator's Manual for technical support information.

CONTACT INFORMATION

Refer to your Steering Controller Operator's Manual for contact information.

VEHICLE INSPECTION

Prior to installing the MDU-G4 system, confirm that the vehicle and the vehicle's steering system are in good working order by driving it around. In addition, verify the following items:

- Verify that you can turn the steered wheels from lock to lock.
- Record the time it takes to turn the vehicle's steering mechanism (ex. steering axle, articulation point) from full left to full right and then record the time to go from full right to full left as fast as you can manually. This will be used later to ensure steering performance is okay.
- Verify the vehicle steers straight and does not pull to one side when driving in a straight line.
- Verify that there are no oil leaks.
- Check for loose or worn steering components.
-

If any part of the vehicle is not in working order, have the system serviced by a qualified technician prior to beginning the MDU-G4 installation procedure.

1 COMPONENTS

This chapter contains the following sections

- Supported Models
- MDU-G4 Main Hardware Kit
- MDU-G4 Switch Kit

1.1 Supported Models

These instructions provide the suggested procedure for installing the MDU-G4 system on qualified vehicles for the easiest installation and best performance. This product is compatible with most vehicles with a three spoke steering wheel with hydrostatic power steering.

Note: The installer can install the AutoSteer system differently than how the manufacturer suggests; however the components that are called out in this manual may not fit properly or the lengths of cables and hoses may not be long enough with alternative mounting solutions. If the installer modifies the installation procedure, it is the responsibility of the installer to ensure all the components will work and that any component with specific orientation and mounting requirements are met.

1.2 MDU-G4 Main Hardware Kit

Note: The kits listed below are used for illustrations purposes. Hardware Kit part numbers will vary between partners.

This section describes the MDU-G4 components required for a typical installation. The installation kit is organized into a main kit that contains a “switch kit” subassembly. The Switch Kit contains the hardware that enables you to switch the MDU-G4 system between vehicles

The MDU-G4 installation may require the components listed below.

Table 1 MDU-G4 Kit

Item	Component	Qty
1.	Mechanical Drive Unit (MDU-G4)	1
2.	MDU-G4 Switch Kit – OEM	1
3.	Anti-rotation Pin Kit	1
4.	Installation Guide	1

The sub-kits that are required for the installation of the MDU-G4 system are provided in this section. Use this section to verify that all the sub-kits and parts required for the installation are available.

Note: All part numbers provided in this manual are subject to change without notice. They are provided as a reference at the time of this writing. Always verify that the part numbers are still valid from your AutoSteer dealer if spare parts need to be ordered.

1.3 MDU-G4 Switch Kit

The Switch Kit components shown in Figura 1-1 enable the operator to move the MDU-G4 between vehicles.

Note: An anti-rotation bracket that fits your vehicle steering column is required to complete the MDU-G4 installation. This bracket varies by vehicle model and must be purchased separately. Contact your MDU-G4 dealer for a list of supported vehicles and available bracket kits.

Figure 1-1 Switch Kit

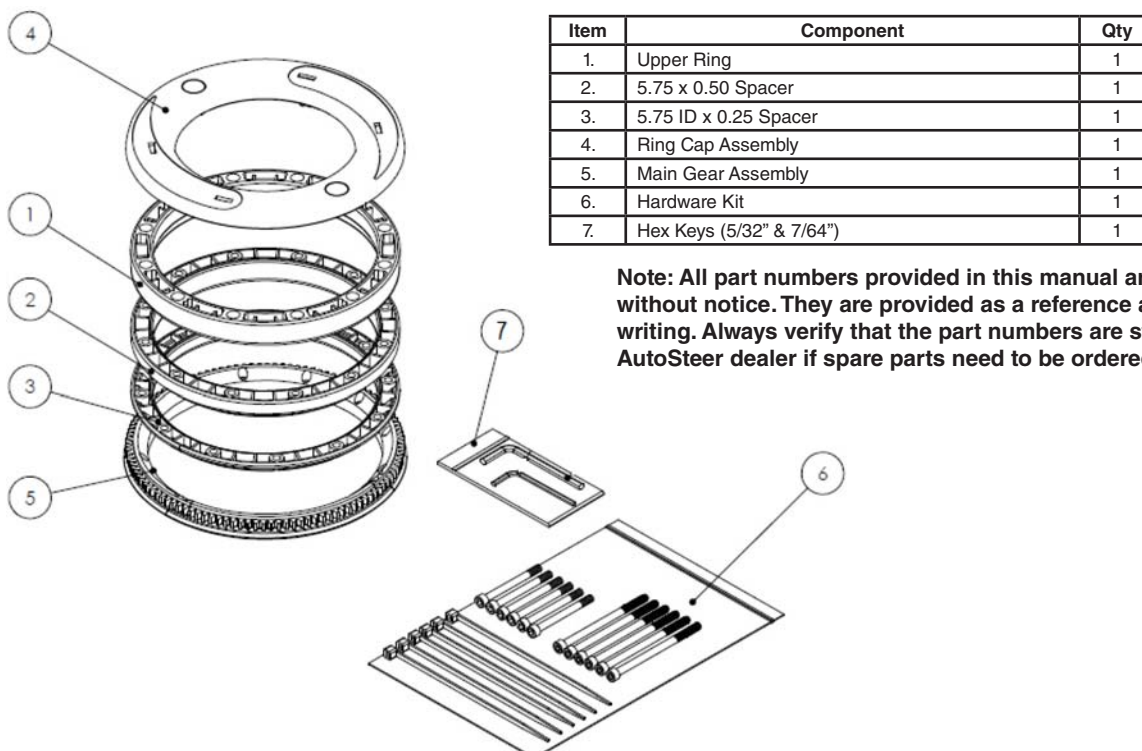

Note: All part numbers provided in this manual are subject to change without notice. They are provided as a reference at the time of this writing. Always verify that the part numbers are still valid from your AutoSteer dealer if spare parts need to be ordered.

2 MDU-G4 INSTALLATION

This chapter contains the following sections

- MDU-G4 Installation Overview
- MDU-G4 Installation Procedure

2.1 MDU-G4 Installation Overview

The MDU-G4 installation process is described below. A detailed process for each step is described in the following sections.

1. Install the Main Gear on the steering wheel
2. Attach the Anti-rotation Pin
3. Install the MDU-G4

2.2 MDU-G4 Installation Procedure

Refer to *Installation Kit Components* in the Components section to identify the parts used in this section.

2.2.1 Install the Main Gear on the Steering Wheel

The goal of this section is the installation of the main gear on the steering wheel. A completed installation is shown in Figure 2-8. Through the use of switch kits, main gears can be installed and left on multiple vehicles allowing the user to move the MDU-G4.

Install the Main Gear around the Steering Column

Figure 2-1 Main Gear Hex Screws

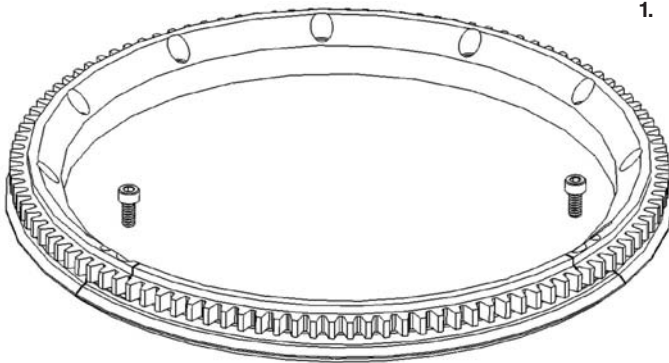

1. Remove the 2 hex screws from the Smaller section of the Main Gear as shown in Figure 2-1

Figure 2-2 Main Gear Smaller Section

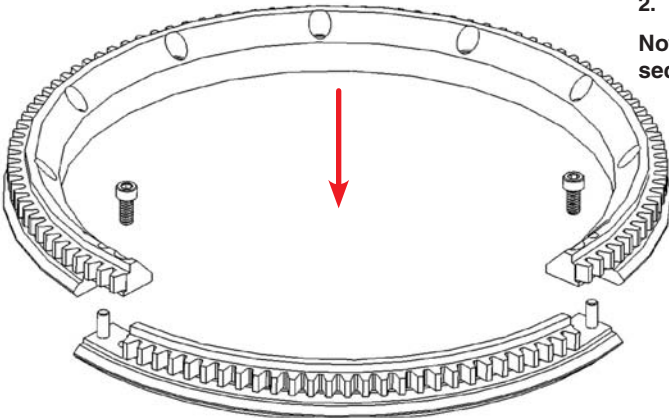

2. Remove the Smaller section by pulling downwards as shown in Figure 2-2

Note: Tolerances are tight, pull directly downwards on the smaller section.

Figure 2-3 Main Gear Installed

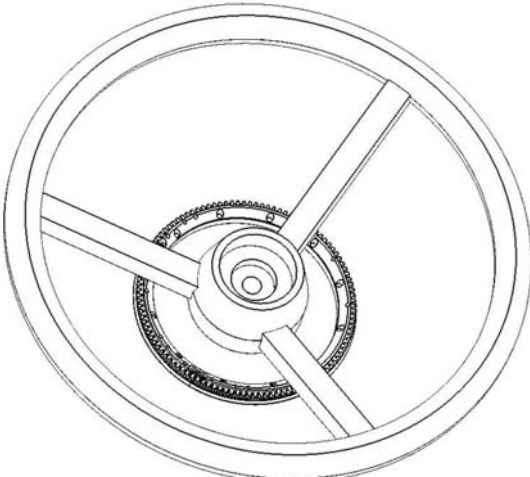

3. Install the larger section under the steering wheel around the steering column. Install with the gear side on the top side, closest to the steering wheel as shown in Figure 2-3

Note: Weave the gear around the steering wheel spokes if necessary, certain columns may be too thick for the gear opening.

4. Reinstall the smaller section using care to push directly upwards on the sector, this is a very tight fit.

Note: To facilitate the fit between the two gear sections, you may need to apply a drop of oil to assist in aligning the two gear sections.

5. Reinstall and secure the 2 hex screws. At this point the main gear is assembled around the steering column below the steering wheel as shown in Figure 2-3. The gear is free to move around and must now be clamped to the steering wheel.

Examine Steering Column and Steering wheel

Examine the steering wheel underside to determine if a spacer is necessary. A steering wheel with a soft covering material usually requires installation of a spacer to avoid interference with the MDU-G4 housing. Flat steering wheels also require the addition of a spacer to prevent interference between the steering wheel and MDU-G4 when the wheel is turned.

Install Spacer (If Needed)

Install the spacer around the steering column between the steering wheel and the main gear as shown in Figure 2-4. Flex the plastic spacer as needed to clear the steering wheel spokes as shown in Figure 2-4. The large chamfer on the outside diameter of the spacer ring should be facing the main gear as shown in Figure 2-4.

Note: Two spacers with different thicknesses are included in the kit. Select the thinnest spacer that provides the sufficient clearance between the steering wheel and the MDU-G4

Figure 2-4 Installing Spacers

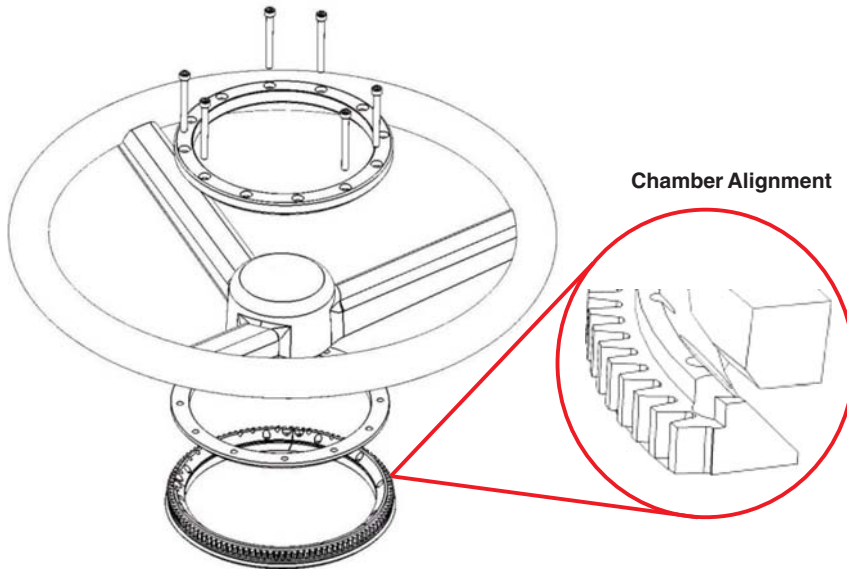
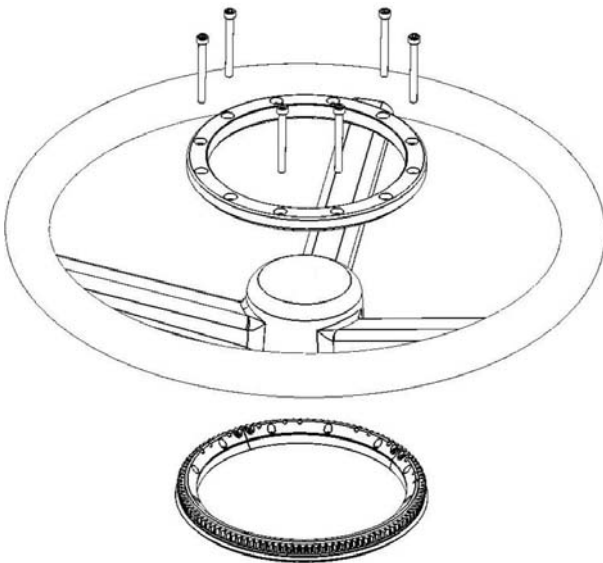

Figure 2-5 Spacer Installation



Install the Clamp Ring

Figure 2-6 Installing Top Ring



1. The gear is free to move around and must be now clamped to the steering wheel. This procedure will install and center the ring gear for typical 3 spoke shaped steering wheels.
2. Place the clamp ring on top of the steering wheel and install a minimum of 6 hex screws. Install a screw on each side of every spoke keeping the screws as close to the spokes as possible. At this stage keep the screws fairly loose to allow for centering. See Figure 2-6

Note: Two lengths of screws are provided in the kit to support different thicknesses of the steering wheel spokes. Select the shorter of the two screws that still provides full thread engagement.

Figure 2-7 Centering Ring Gear



3. With the main gear clamped loosely, rotate and move the gear until 3 screws touch the three spokes evenly. Figure 2-7 shows the main gear rotated counter-clockwise until three of the mounting screws touch the steering wheel spokes evenly. This procedure will help to automatically center the gear under the steering wheel.

The red circles indicate which screws are touching the spokes.

Figure 2-8 Installing Plastic Cover

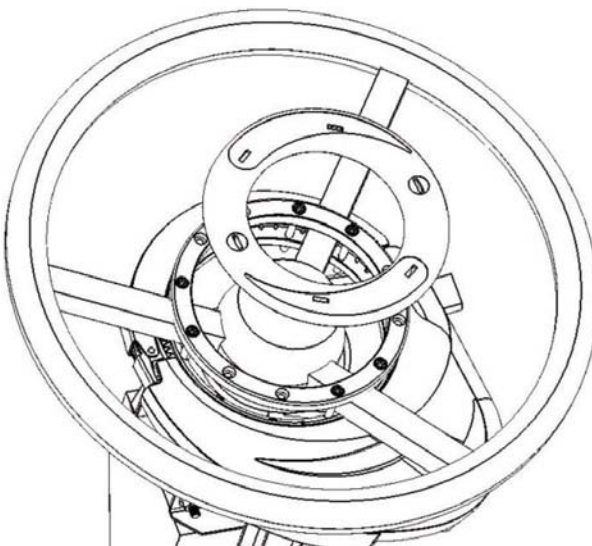

4. Check the installation by rotating the steering wheel and watching for off-center movement of the main gear. Repeat the centering process as necessary.
5. Tighten the screws with an Allen key. Torque to 6 in-lb (0.7 Nm). Tighten the screws in a cross-pattern (as opposed to tightening each screw in a clockwise or counter-clockwise order).

Note: Do not over-tighten the clamp ring screws. This may cause the ring gear to warp or damage the steering wheel spokes.

6. Check the installation again after tightening by rotating the steering wheel and watching for off-center movement of the main gear. Repeat the centering process as necessary.
7. Snap the plastic cover over the top ring as shown in Figure 2-8

2.2.2 Attach the Anti-Rotation Pin

1. Choose the desired MDU-G4 orientation. The MDU-G4 can be mounted in any orientation the user chooses. Consider the following when choosing an orientation:
 - Ease of installing anti-rotation bracket.
 - Access to the Power Switch.
 - Avoid locations where a knee could accidentally press the power switch.
 - Avoid blocking the vehicle's steering column controls and indicators.
 - Cable routing with minimal obstruction in the cab.
2. Based on your preferred orientation, choose one of three locations for the Anti-rotation Pin as shown in Figure 2-10

Figure 2-9a Anti-rotation Pin Kit

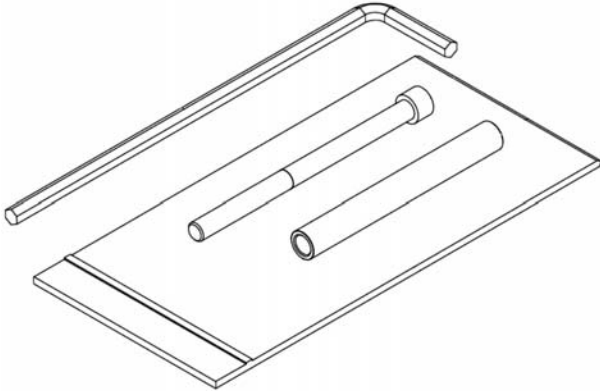
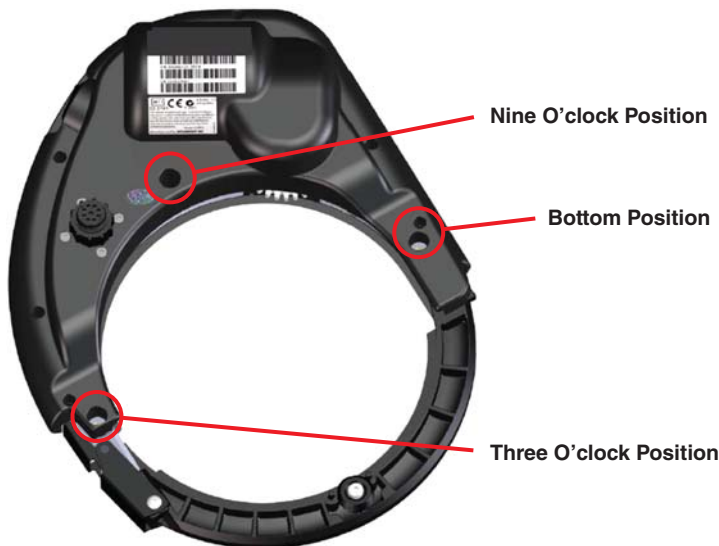

Figure 2-10b Anti-rotation Pin Locations



3. Assemble the anti-rotation pin by inserting the long screw through the metal sleeve provided.
4. Install the anti-rotation pin under the MDU-G4 in one of the three positions and tighten to 100 in.lbs (11.3 Nm) using the 3/16" hex key (Allen key) provided.

Note: The anti-rotation pin must always be kept tight to avoid breakage or separation. Periodically check the anti-rotation pin and confirm that it is tight. Always tighten to the specified torque.

2.2.3 Install the MDU-G4

This procedure describes the installation of the MDU-G4 to the Main Gear

1. Open the MDU-G4 release latch as shown in Figure 2-11

Figure 2-11 Release latch

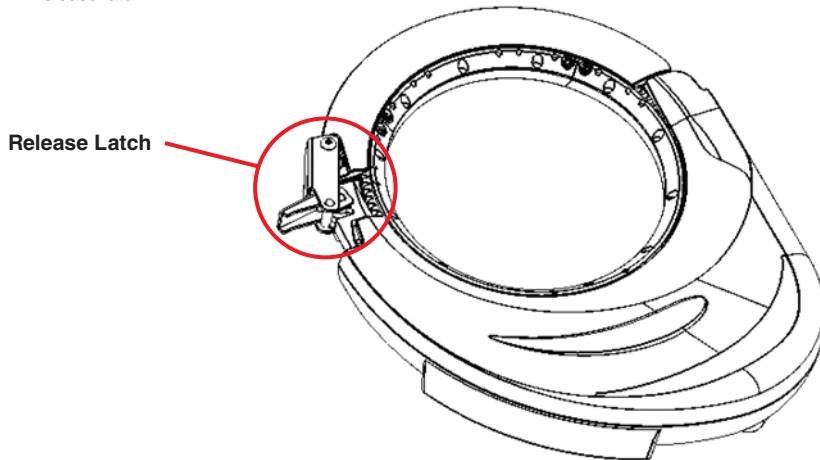

2. Fit the MDU-G4 around the Main Gear so that the three MDU-G4 rollers align on the Main Gear race as shown in Figure 2-12

Note: The plastic cover on the MDU-G4 can be used as a guide to fit the bottom portion of the MDU-G4 to the V-rollers

Figure 2-12 Roller Engagement

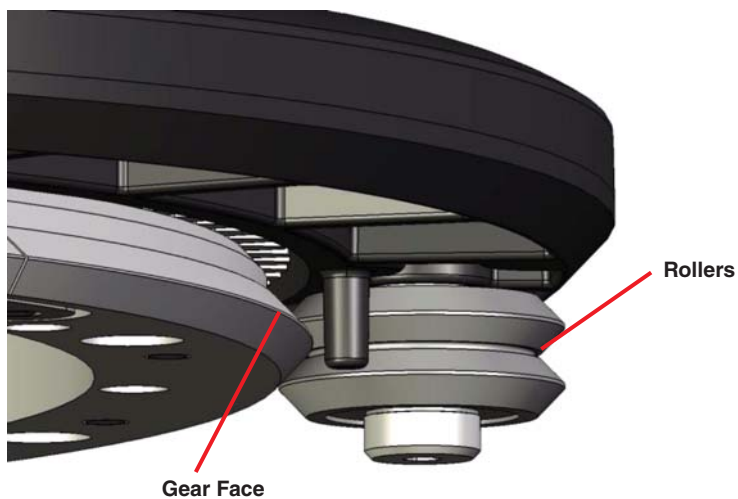

3. Ensure that the main gear race has properly engaged the three rollers before closing latch. See Figure 2-11
4. Rotate the MDU-G4 manually to ensure smooth rolling operation.

3 UNIVERSAL BRACKET INSTALLATION

This chapter contains the following sections:

- Universal Bracket Installation

The universal anti-rotation bracket is available through your dealer. It should be used for vehicles that are not supported with a custom vehicle-specific bracket. Consult your AutoSteer dealer for a list of all available anti-rotation brackets. An Anti-rotation bracket is required to complete the MDU-G4 installation.

Note: A different bracket may be required depending on your specific vehicle. Contact your AutoSteer dealer for details

Note: If you are installing a custom specific vehicle anti-rotation bracket, skip this section and refer to the instruction manual provided with your vehicle specific anti-rotation bracket kit.

3.1 Universal Bracket Installation

The following section describes the procedure for installing the Universal Anti-rotation bracket

- Overview
- Procedure

3.1.1 Universal Bracket Installation Kit Overview

To complete your MDU-G4 installation and prevent the rotation of the MDU-G4 (Mechanical Drive Unit), an anti-rotation bracket must be mounted to the vehicle steering column just below the steering wheel. This chapter provides instructions for installing a universal bracket kit that is available as an accessory through your AutoSteer dealer. Many other brackets are available to fit specific vehicles models and can be ordered through your AutoSteer dealer. Contact your dealer for details and availability for your vehicle model.

The typical universal bracket kit includes the components shown in Figure 3-1

Figure 3-1 Universal Anti-rotation Bracket

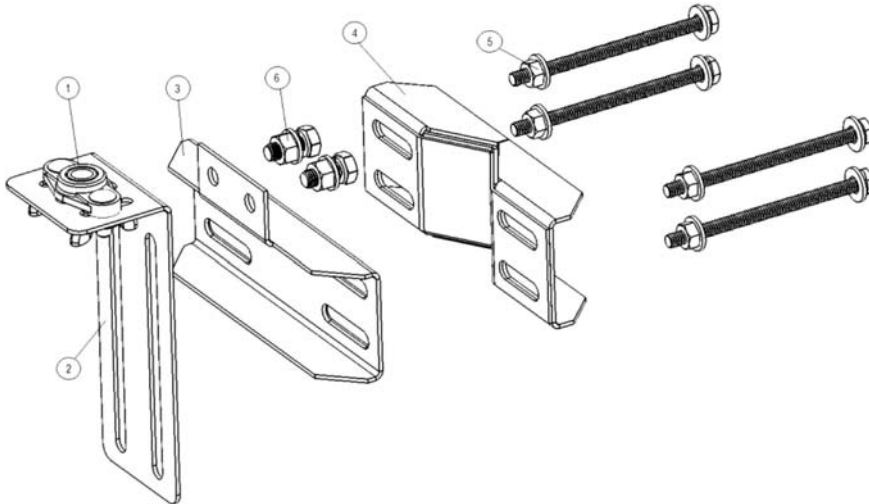

Item	Component	Qty
1.	Flange Bearing	1
2.	Fifth Wheel Slider	1
3.	Front Bracket	1
4.	Back Bracket ('V' shape)	1
5.	Clamping screws. Machine Screw Phillips 1/4 - 20 x 4" (Washers, Lock Washers and Nuts)	4
6.	Bolts 5/16 -18 x 3/4" (Slider Attaching Bolts)	2

3.1.2 Universal Bracket Installation Procedure

Note: The MDU-G4 is attached to the steering wheel prior to installation of the bracket kit.

1. Make sure that you have all of the required parts. Figure 3-1
2. Attach front bracket to the fifth wheel slider bracket using the two bolts (slider attaching bolts). See Figure 3-2
Tighten finger tight.

Note: The slider bracket will require adjustment once installed on the steering column.

Figure 3-2 Slider Attachment Bolts

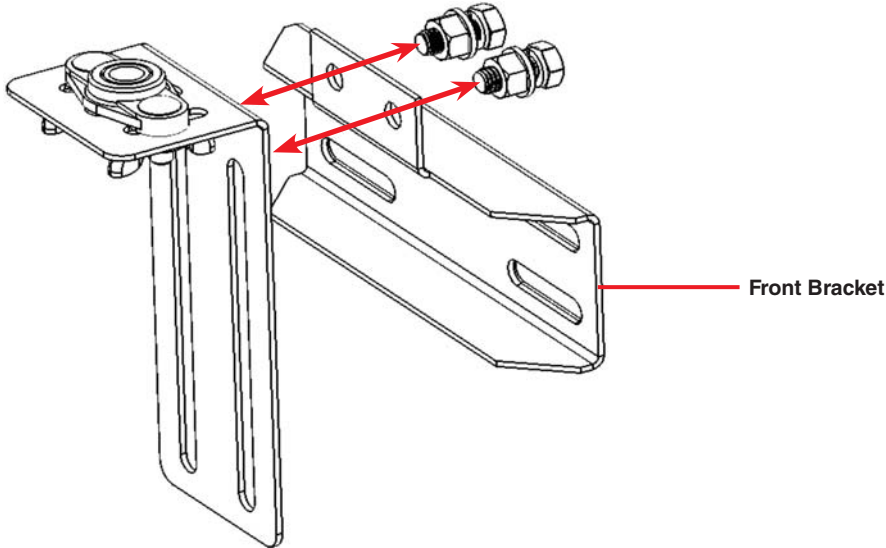

3. Place the flange bearing assembly over anti-rotation pin. Figure 3-3

Note: It is important that the anti-rotation pin is placed through the flange bearing before attaching the Fifth Wheel Bracket

Figure 3-3 Anti-rotation Pin Engagement

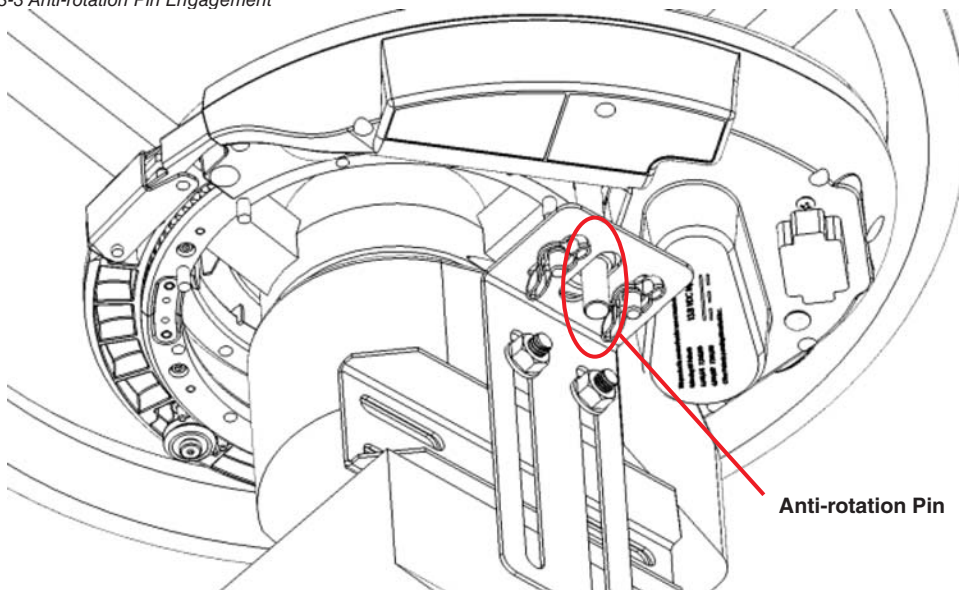

- 4. Attach the back bracket to the front bracket using the four machine screws clamping the steering column between the front and back brackets.
Figure 3-4

Figure 3-4 Back Bracket Installation

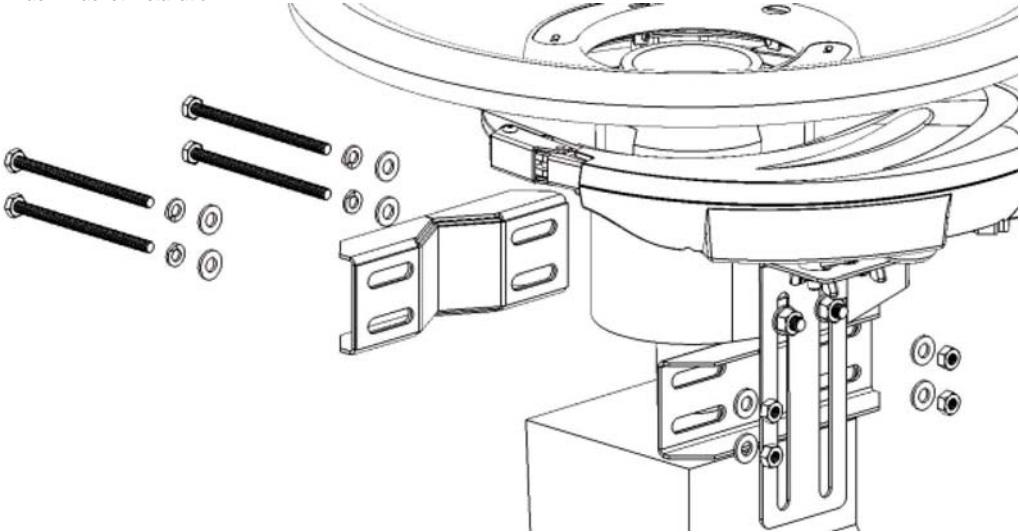

- 5. Tighten the clamping assembly.
- 6. Adjust the position of the fifth wheel slider so the flange bearing is approximately in the middle of the anti-rotation pin and tighten the bolts (Slider attaching bolts).

Figure 3-5 Slider Bracket Engagement

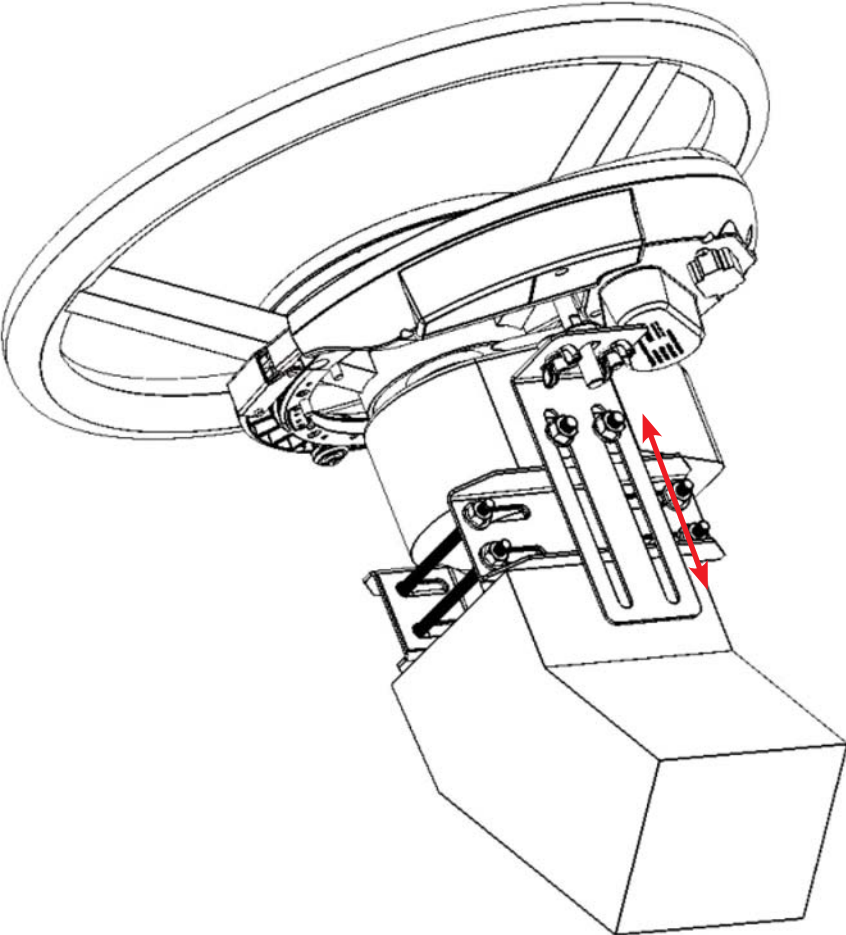

The bracket installation is complete.

4 CABLE HARNESS INSTALLATION

This chapter contains the following sections:

- Overview
- Cable Harness Installation Procedure

4.1 Overview

4.1.1 Safety Notes

Note: The vehicle must be power off during the installation of cable harness

Note: To prevent the system from any unexpected shut down while operating, check the cable insulation and cable connections to the other instruments. Route the cables away from all sharp edges to prevent control wires from being pulled hard or damaged.

4.1.2 Cable Harness Connections Overview

The typical Cable Harness installation includes the components shown in Figure 4-1. For a detailed cable connection procedure, see Cable Harness Installation Procedure on page 17.

Figure 4-1 MDU-G4 Harness Components

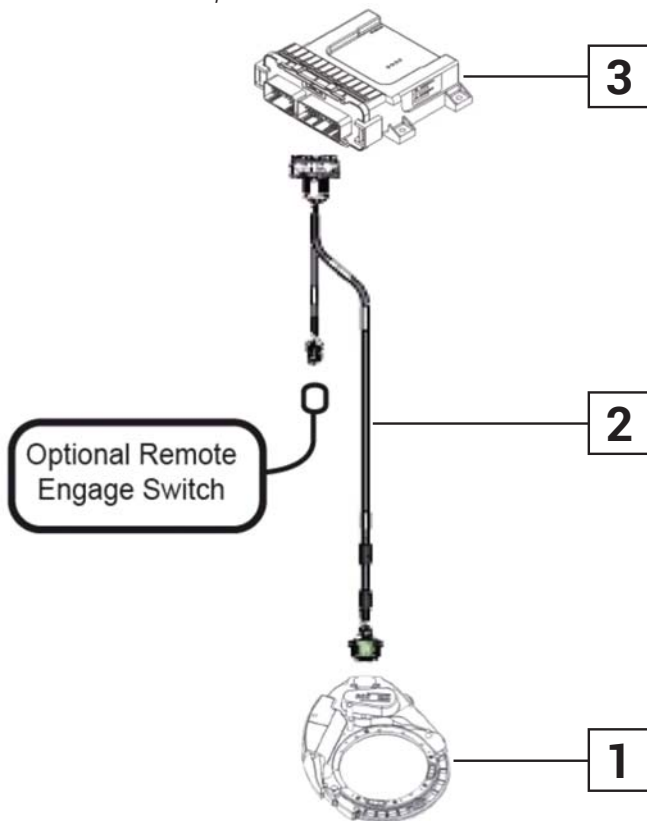

Item	Description
1.	MDU-G4 to ECU Cable Harness
2.	Mechanical Drive Unit (MDU-G4)
3.	Electronic Control Unit (ECU)

4.2 Cable Harness Installation Procedure

The MDU-G4 GPS Assisted Steering System cable harness installation steps are described below. Follow them in order, referring to Figure 4-1 as necessary. This procedure assumes that you have connected your Steering Controller (ECU) to your Display Harness and Power. Refer to Steering Controller (ECU) documentation for further information.

1. Connect the MDU-G4 to ECU Cable Harness 30 pin connector to the ECU and tighten the connector screw using a 1/4" nut driver. Tighten to 15 to 20 in-lbs (1.7 to 2.2Nm). Use only the recommended nut driver and do not over tighten. Figure 4-2

Figure 4-2 Connect Harness to ECU

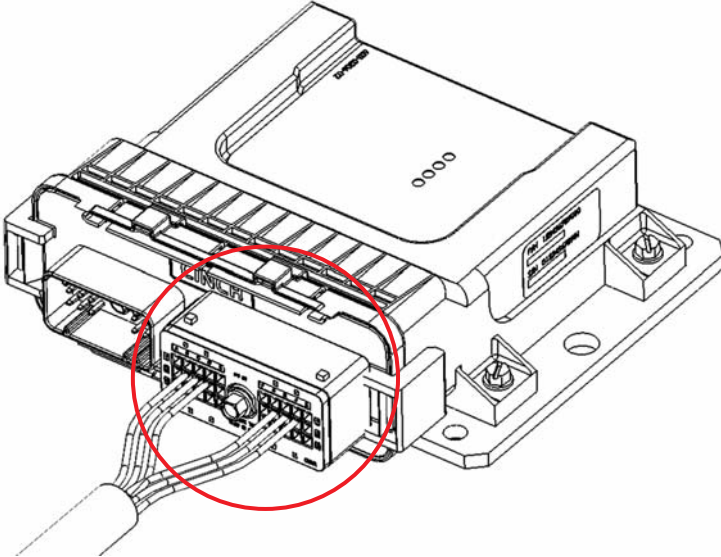

2. Connect the MDU-G4 Harness to the MDU-G4 as shown in Figure 4-3 . Carefully align the circular connector against the mating connector under the MDU-G4 and rotate until it fits. Then rotate the external sleeve clockwise to lock the connector. To disassemble, rotate the outer connector sleeve counterclockwise. Never force the connector

Figure 4-3 MDU-G4 Harness to MDU-G4 Connection

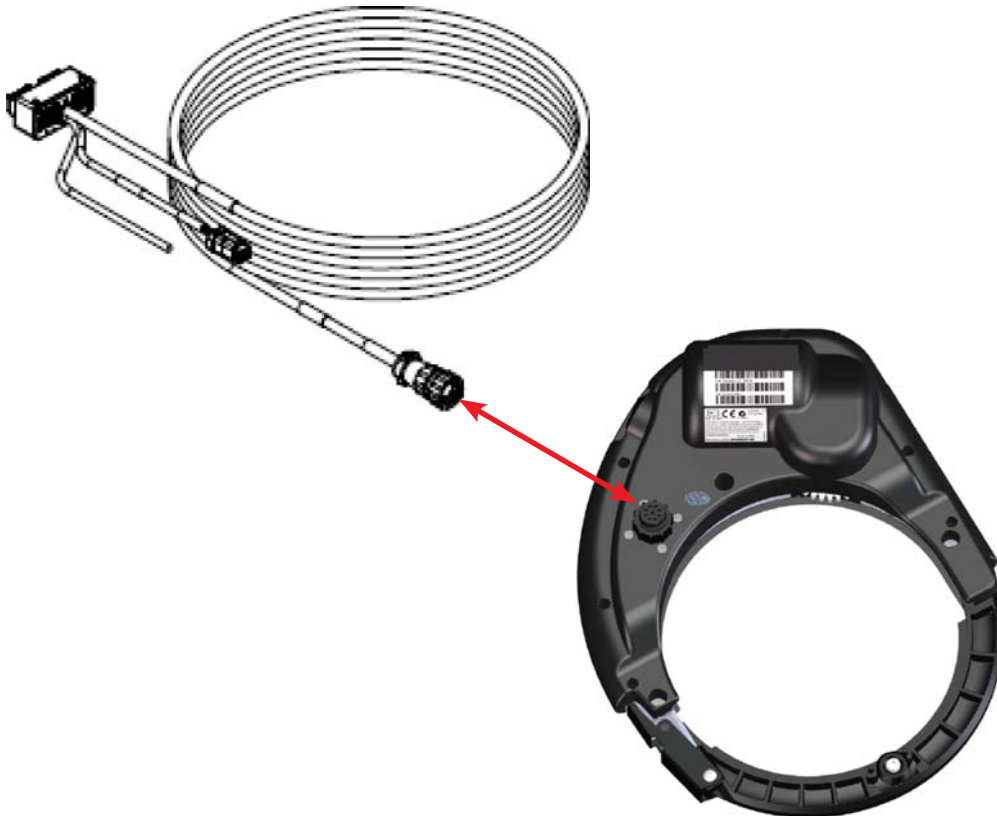

3. Route the cables in such a way to prevent damage.
4. Installation of the MDU-G4 is complete refer to the Steering Controller Operators Manual for vehicle setup and calibration and operation instructions.

5 ON/OFF SWITCH

This chapter contains the following sections

5.1 Overview

MDU-G4 is equipped with an On/Off switch and LED diagnostic lights. The following sections cover the function of the switch and the lights

Figure 5-1 On/Off Switch



5.2 On/Off Switch

The MDU-G4 is equipped with an On/Off switch as shown in this allows the operator to disable the MDU-G4 unit without powering down the complete steering controller. Position the switch with the 0 to disable the MDU-G4

Figure 5-2 Led Lights

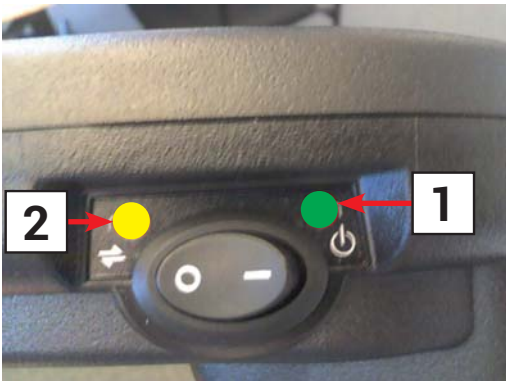

5.3 Led Lights

The MDU-G4 has 2 LED lights

- When the MDU-G4 is powered, light 1 will be a constant Green Figure 5-2
- When a steering command is given to the MDU-G4 light 2 will flash Yellow when the wheel is turning. Figure 5-2

6 CARE AND MAINTENANCE

This chapter describes the required care and maintenance for your MDU-G4 system. Should you require repair services, spare parts or warranty, contact your MDU-G4 dealer. Only the factory or an authorized service center has the correct parts and training necessary to service your MDU-G4 system.

- Keep the anti-rotation pin tight at all times. Check the anti-rotation pin every 250 hours of operation or every six months, whichever occurs first, and tighten as necessary to the specified torque. Do not operate the MDU-G4 unit if the anti-rotation pin is loose.
- Keep the anti-rotation bracket well secured to the steering column at all times. Check the anti-rotation bracket every 250 hours of operation or every six months, whichever occurs first, and confirm that it is secure and all fasteners are tight. Tighten as necessary.
- Keep the Electronic Control Unit (ECU) and associated brackets well secured to the vehicle at all times. Verify that the ECU is secure every 250 hours of operation or every six months, whichever occurs first, and tighten as necessary. Do not operate the MDU-G4 system if the ECU is not well secured. A detached ECU may cause sudden loss of vehicle control while in AutoSteer mode.
- Do not expose your Mechanical Drive Unit (MDU-G4) to water or rain. Store the MDU-G4 in a protected location. On open platform tractors, remove it from the vehicle when not in use.
- Check all cables and electrical connectors every six months. Secure any loose cables using cable ties.
- Clean the outside surfaces of your Mechanical Drive Unit and the three guide rollers using a damp cloth. Do not apply spray cleaners, spray waxes, liquids or lubricants such as WD-40. The use of any liquid cleaning agent or lubricant may damage the internal components of your Mechanical Drive Unit and will void the factory warranty.
- Always clean the main gear and main gear race (see Figure 2-12) with a damp cloth to remove dust before installing the MDU-G4 to the steering wheel. This is especially important when moving the MDU-G4 between vehicles.
- The Mechanical Drive Unit is manufactured with sealed bearings and self lubricating components and does not require lubrication. Do not apply oil, grease or spray lubricants.

