

# FULL PACKAGE KIT INSTALLATION MANUAL - RX SERIES

**Available for:**  
RX Series – Utility tractors, 66–74 hp

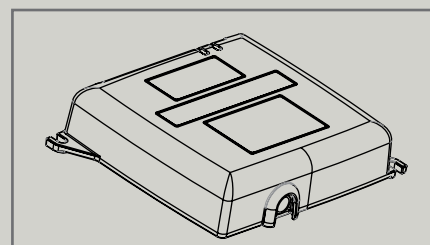
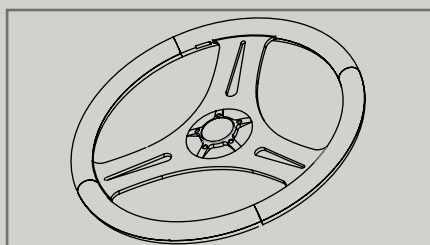
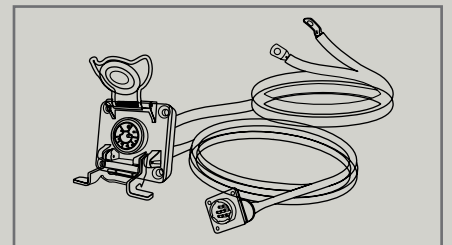
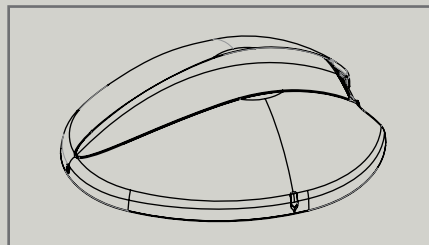
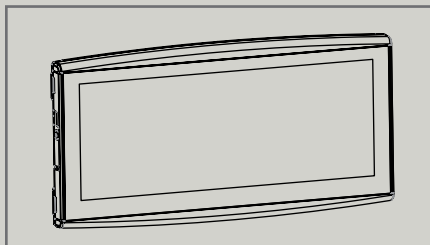

# 1. Packing list

No.	Description
<b>1</b>	<b>Farmnavigator G12</b>
1.1	G12
1.2	ISOBUS In-cab cable
1.3	USB, Ethernet, Video (x2) cable
1.4	Power & I/O cable
1.5	RAM arm
<b>2</b>	<b>All in One RTK</b>
2.1	Receiver
2.2	Receiver cable
2.3	Receiver bracket
2.4	3M double-sided tape
<b>3</b>	<b>4G Agri SIM</b>
3.1	Modem
3.2	Power cable
3.3	CAN inductive reader
3.4	CAN inductive reader cable
<b>4</b>	<b>Isobus Retrofit Cable</b>
4.1	Isobus Retrofit Cable set
<b>5</b>	<b>Pilota</b>
5.1	Steering wheel kit
5.2	Motor + Wiring Harnesses
5.2.1	Motor
5.2.2	Device Cable
5.2.3	Power Cable
5.2.4	Motor Cable
<b>6</b>	<b>Installation Kit</b>

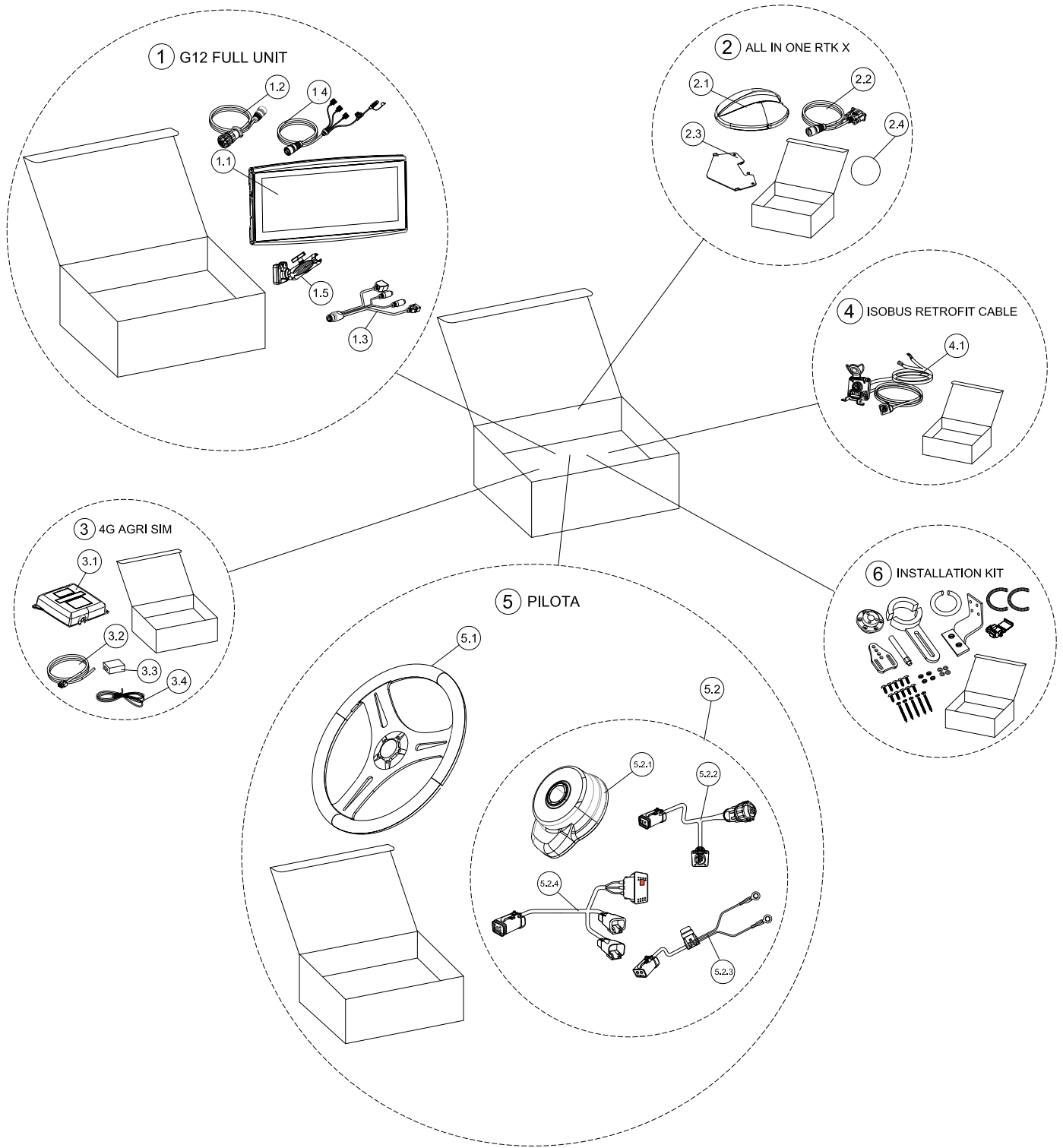

## **2. General Safety Information**

### **2.1 Before servicing and repairing**

- Read all safety instructions in this manual and be aware of safety decal locations on your machine.
- Thoroughly clean your work area and the machine before starting any operation.
- Make sure the machine is on firm and level ground and the parking brake is applied.
- Lower all implements to the ground.
- Stop the engine and remove the ignition key.
- Disconnect the negative battery cable before performing any electrical work.
- Place a “DO NOT OPERATE” tag in the operator station to warn others

### **2.2 Before installing the FARMNAVIGATOR PILOTA AutoSteering system**

- Read all instructions completely before starting the installation or calibration of the AutoSteering system.
- Use appropriate tools to remove the steering wheel, taking care not to damage steering components or the steering column.
- Verify that the tractor steering is in good mechanical condition before installing the electric motor.
- Make sure the steering can turn fully to the left and right without obstruction before and after installation.
- Stop the installation immediately if excessive play is found in the steering column coupling, and contact qualified service personnel.
- Perform all installation operations on firm, level ground with the vehicle safely parked and the engine off.

### **2.3 Working safety**

- Do not operate or service the machine while under the influence of alcohol, medications, or other substances that may impair judgment or reaction time.
- Never wear loose-fitting clothing near moving parts. Always use personal protective equipment (PPE) appropriate to the task.
- Never use improvised tools or non-approved parts. Use only tools recommended for the specific operation.
- Exercise extra caution when working alongside other people. Communicate clearly before performing any action on the machine.
- Always support the machine with safety stands rated for the weight of the vehicle.
- Do not touch any rotating or hot parts while the engine is running.
- Escaping hydraulic fluid under pressure can penetrate the skin and cause serious injury. Always relieve system pressure before disconnecting hydraulic or fuel lines. Retighten all connections before reapplying pressure.

- Keep work areas free from obstacles, spilled fluids, and debris to prevent slipping or tripping hazards.

### **2.4 Electrical safety**

- Always disconnect the negative battery cable before performing work on electrical components.
- Connect battery leads only as specified in this manual. Incorrect polarity can cause irreversible damage to electronic modules and risk of fire.
- Route all replacement cables away from moving parts, hot surfaces, hoses, and alternators.
- Do not short-circuit battery terminals. Use insulated tools when working near live electrical connections.

### **2.5 FARMNAVIGATOR PILOTA AutoSteering — operational safety**

- The operator must remain seated and alert at all times while AutoSteering is active. Automatic steering does not replace operator supervision.
- The operator is fully responsible for the safe operation of the vehicle at all times, including when AutoSteering is engaged.
- Disengage AutoSteering immediately if the electric motor causes abnormal stress, eccentric rotation, unusual noise, or obstruction of steering wheel movement.
- Do not engage AutoSteering in the vicinity of people, animals, obstacles, road traffic, slopes, ditches, or in any situation that may require immediate manual intervention.
- Always verify that the AutoSteering system has been correctly calibrated before first use and after any intervention on steering components or mounting hardware.
- Do not modify, bypass, or alter the AutoSteering system software, firmware, or hardware in any way not explicitly authorised by the manufacturer. Unauthorised modifications void the warranty and may create safety hazards.
- In the event of abnormal system behaviour (unintended steering, loss of GNSS signal, or software error), disengage the system immediately using the designated override control and resume manual operation.

### **2.6 Disposal of fluids and materials**

- Observe all applicable environmental protection regulations when disposing of oil, hydraulic fluid, fuel, coolant, and batteries.
- Never pour fluids onto the ground or into drains, rivers, or any body of water.
- Collect used fluids in appropriate sealed containers and deliver them to authorised collection or recycling centres.

### 3. Installation instructions

The Full Package Kit includes an installation kit with all components required for a successful installation. Each component is identified by a letter in the image below.

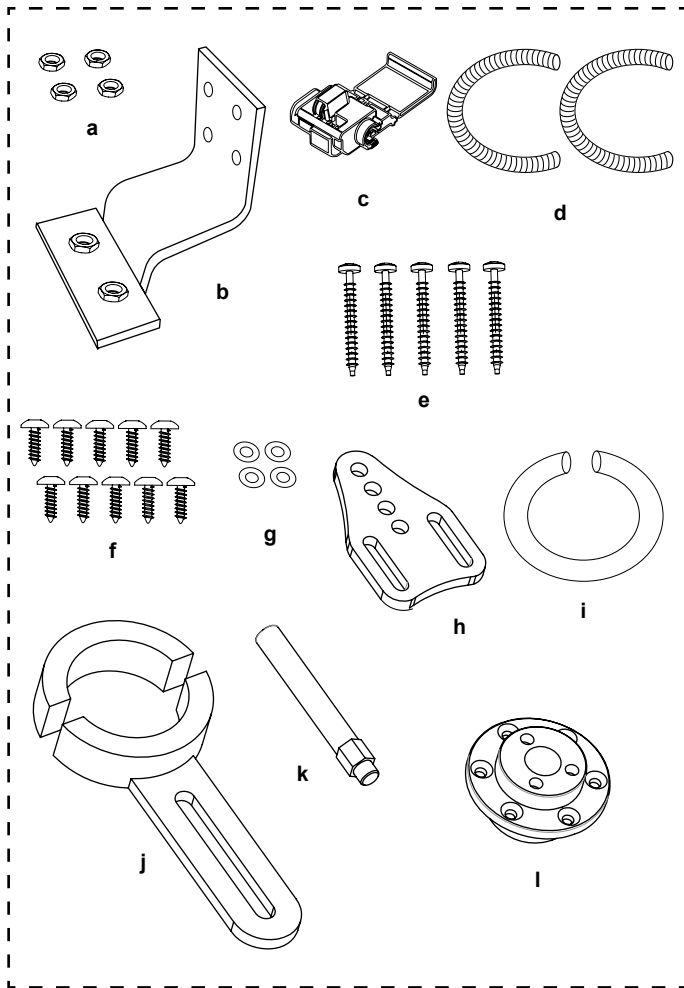

#### 3.1 Installation of ISOBUS retrofit cable

The ISOBUS retrofit cable (4.1) consists of 3 parts: main cable, IBBC connector, cab socket cable. The following is a list of the three components, where each single connection point is identified by a capital letter between squared brackets.

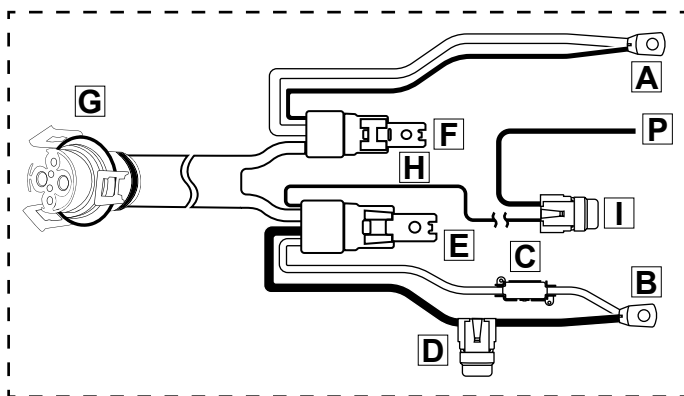

4.1.1 Main cable

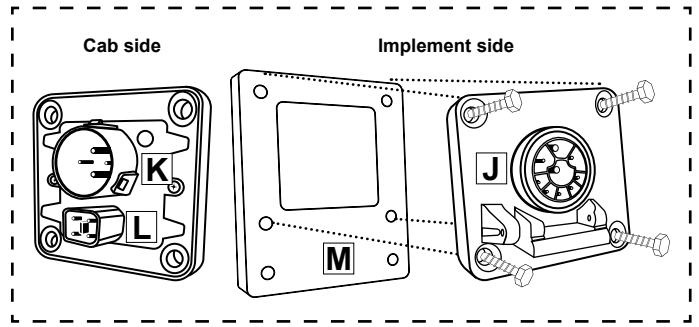

4.1.2 IBBC connector

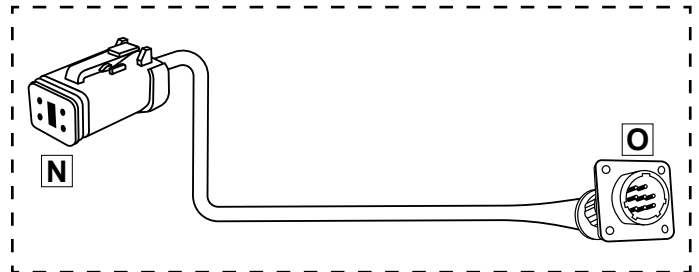

4.1.3 Cab socket cable

1. Locate the battery compartment, located under the frontal cover of the tractor. The two terminals will be visible.



- Remove the two nuts and the metal plate above the air duct. Use this space to route the main cable (4.1.1).



- Route the main cable up to the back part of the tractor. When routing the wire harness, secure it only to rigid parts. Do not attach it to high-pressure hydraulic hoses or to any moving parts or linkages.
- Position the main wiring harness connector [G] on the rear left side of the tractor, near the license plate mounting bracket.



- From inside the cab, on the lower right side, remove the square plastic cover. Inside the compartment,

there is a passageway to the bottom of the tractor. The passage is lined with foam, pull it upward and use this passageway to route the cables from the outside into the inside of the tractor.

- Route the cab socket cable (4.1.3) so that the connector [N] exits the tractor through the indicated opening until it reaches the area near the mounting bracket for the rear license plate. Keep the connector [O] inside the compartment.

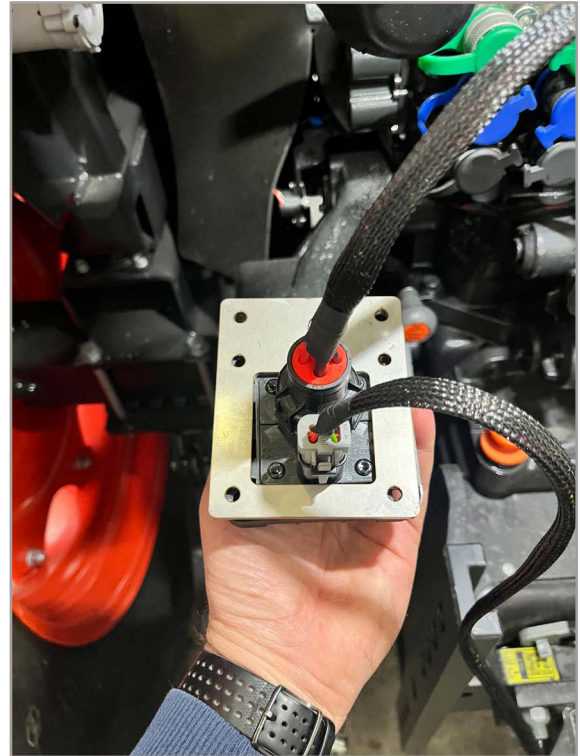

- Connect connectors [N] and [G] to the IBBC connector (4.1.2).



- Attach the bracket [M] to the license plate mount using the screws (e) provided in the installation kit.



- Inside the tractor cab, lift the control panel on the right side of the seat (by removing the mounting screws).

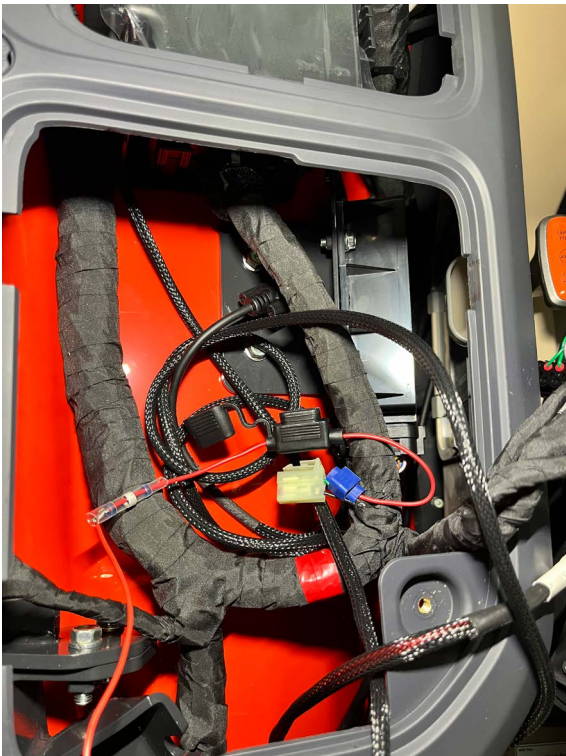

- On the right side of the compartment, beneath the control panel just lifted, locate a two-wire connector (black, green). The green wire is the ignition wire. Connect the fuse holder [H] to the ignition wire.

- Run the cable [I] under the panel to the location of the fuse you just installed.

- Connect the terminals of the main cable (4.1.1) to the battery.

### **3.2 Installation of 4G AGRI SIM**

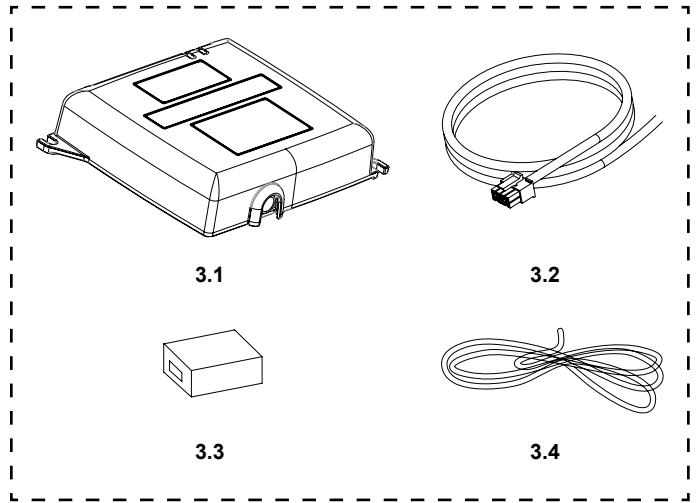

- On the back of the modem (3.1), remove the two mounting screws and connect the power cable (3.2).



2. Locate the OBD connector in the lower right compartment. Remove the two mounting screws and locate the white and red wires corresponding to pins CANH (pin 14) and CANL (pin 6).



3. Open the CAN inductive reader (3.3) and lay out the white and red wires inside.

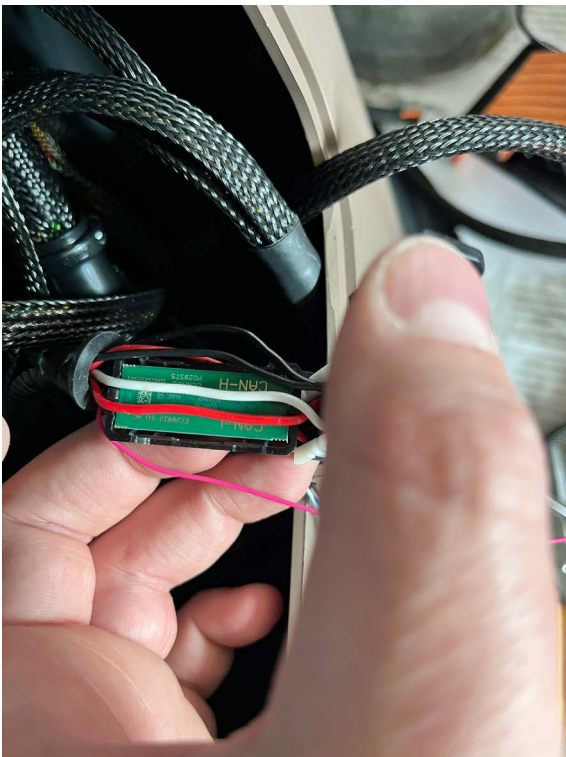

4. Close the cap of the CAN inductive reader (3.3), taking care not to pinch the wires. Then insert the wiring harnesses (3.4) into the connector (3.3). Finally, refit the OBD connector in its original position and secure it with the two screws.



5. Connect the wires according to the following diagram:

Signal	Power Cable (3.2)	CAN inductive reader Cable (3.4)
CANH	Yellow	White blue
CANL	Green	Blue
GND	Black	Black
Battery (+)	Red	Connect to battery positive
Ignition	Blue	Red

**Note:** Use scotchlocks (c) provided in the Installation kit to connect GND, Battery (+) and Ignition signal to the selected power lines.

6. Run the cable under the panel to the location of the fuse installed before. Connect the ignition wire to the fuse. Then:
  - the GND wire on the back of the OBD connector, to pin 4;
  - the red wire (battery) to pin 16 of the OBD connector.



7. Place firmly the modem (3.1) inside the compartment.

### **3.3 Installation of the GNSS receiver**

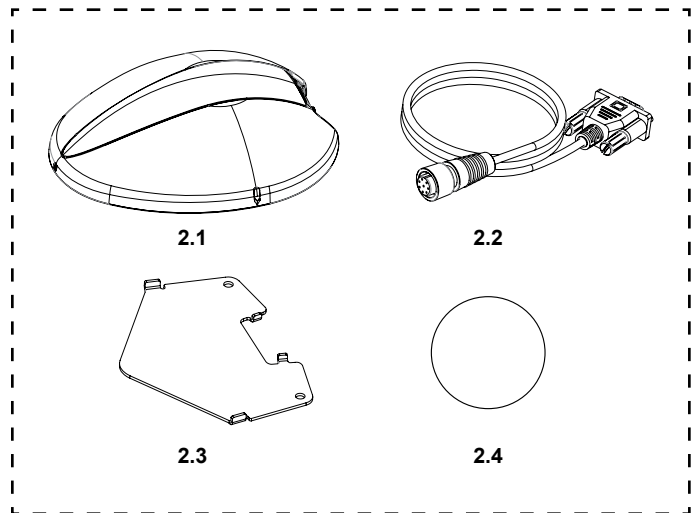

1. Attach the 3M double-sided tape (2.4) to the receiver bracket (2.3). Then connect the receiver cable (2.2) to the receiver (2.1).
2. Measure and mark the center of the tractor (right and left). Clean the area with a cloth and degreaser. Remove the protective film from the 3M double-sided tape and attach the receiver, ensuring the cable points toward the rear of the vehicle. Make sure the receiver is securely attached, correctly oriented, and positioned away from other electronic devices.

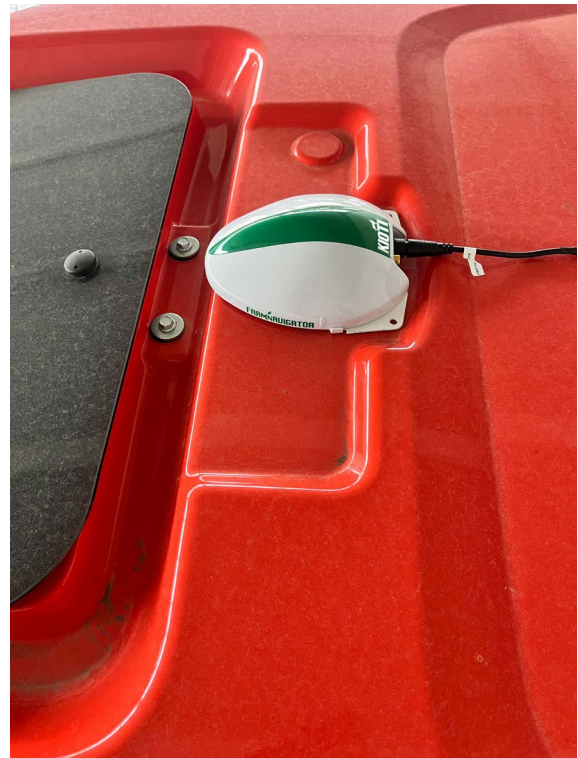

- Route the antenna cable near the right taillight. Then feed the cable under the roof into the rear right corner of the cab, as shown in the detail - red circle. Secure the cable to the taillight with a cable tie.



- Inside the cabin, remove the right rear bracket, then feed the antenna cable inside and down into the compartment beneath the right control panel.



- The receiver cable and the ISOBUS In-CAB cable are easily accessible inside the cab.

### 3.4 Installation of the G12

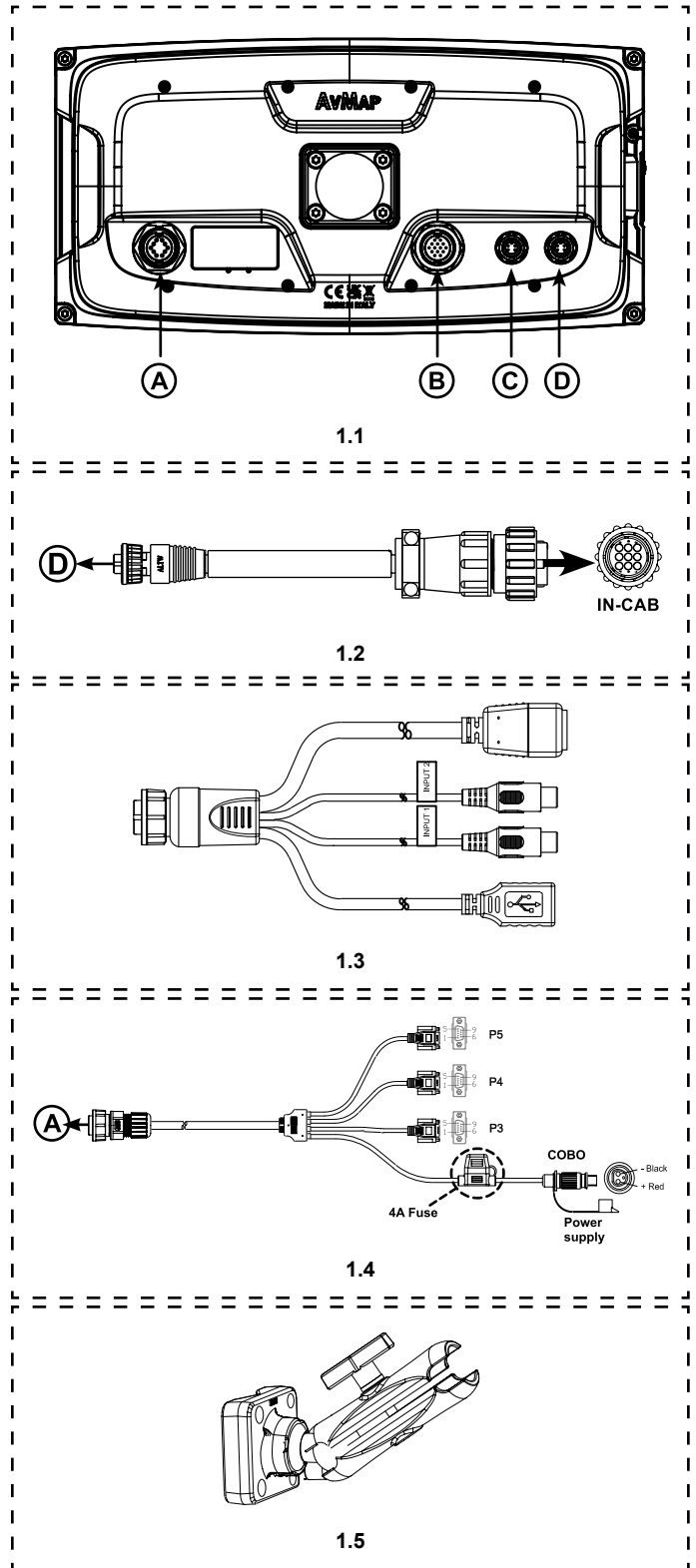

1. Use the two U-brackets - (d) in the installation kit - and the RAM ball to build a mounting bracket and secure it on the bar of the right side of the tractor.
3. Connect the P4 connector labeled "GPS" on power & I/O cable (1.4) to the 9-pin rectangular connector on the receiver cable.



2. Attach the arm (1.5) to the mounting bracket, then secure the G12 (1.1). Connect power & I/O cable (1.4) and ISOBUS In-cab cable (1.2) USB, Ethernet, Video (x2) cable (1.3) is optional and is used for USB and cameras.

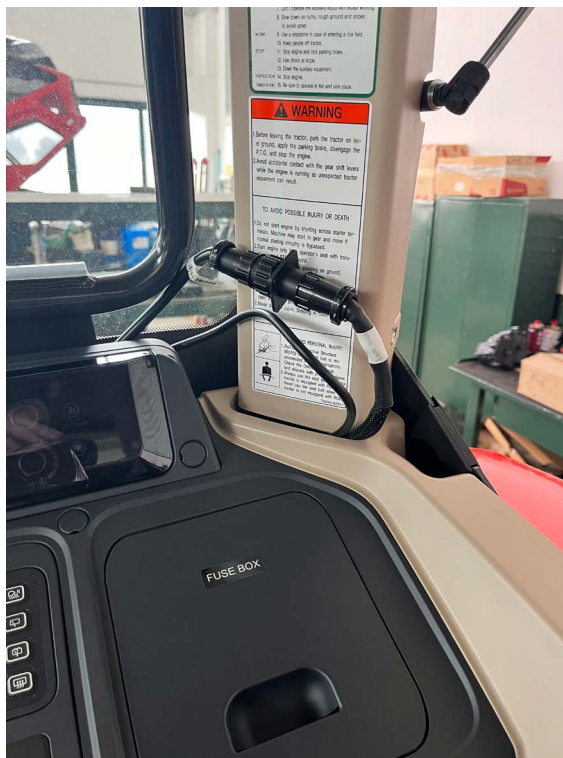

4. Then connect the ISOBUS In-CAB cable connector (1.2) to the 9-pin circular connector [O] on the cab socket cable (4.1.3)

**Note:** For installations that include automatic steering, the ISOBUS In-cab cable (1.2) must be connected to the Pilota's device cable and specifically to the connector labeled "TO DISPLAY".



5. Connect the G12's power line (3-pin connector - see 1.4) to the mating socket in the cab.
6. Once all components have been properly secured, close all opened panels and covers, restoring them to their original condition. Ensure that all wiring is routed internally and does not interfere with moving parts, linkages, or components that may overheat during vehicle operation. Then reconnect the battery terminals.

### 3.5 Installation of the Pilota

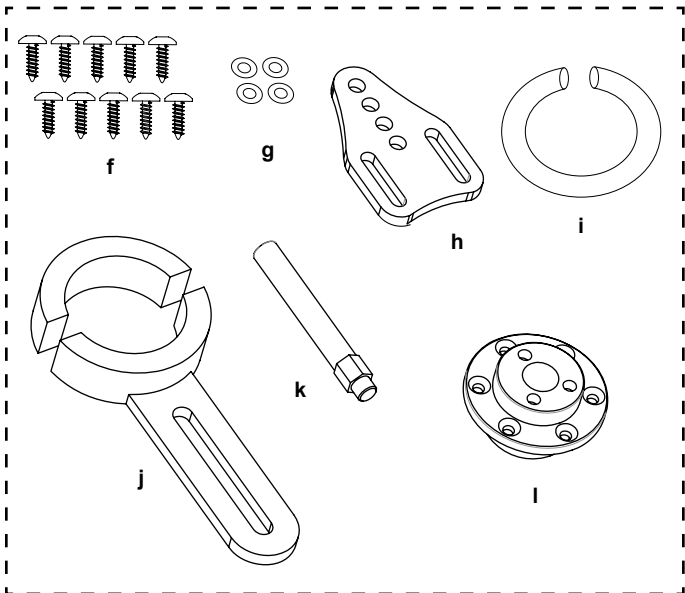
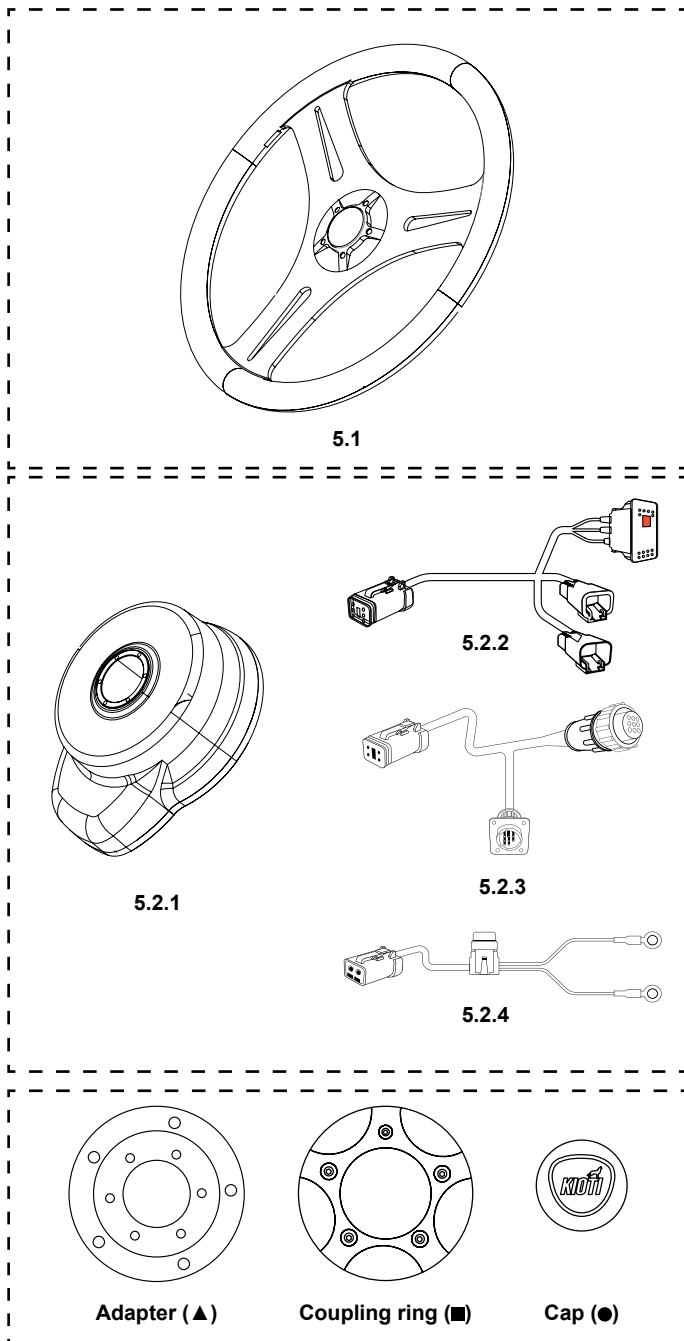

1. Using the screws provided (f), secure the adapter (▲) to the motor (5.2.1), applying a strong threadlocker. Then, secure the coupling ring (■) and the handwheel (5.1) to the adapter (▲) using the screws provided.



- Secure the spline adaptor (l) to the back of the motor using the screws provided and tighten them with strong threadlocker. Make sure the spline adaptor is properly centered and that the screws are tightened securely.



- On the tractor, remove the center cap of the steering wheel, the nut, and the lock washer.
- Using the appropriate tools, remove the steering wheel.



- Secure the anti-rotation plate (h) to the back of the motor using the screws and washers (g) provided. Secure the anti-rotation pin (k) to the plate, including the washer provided.



- Remove the six screws securing the front plastic steering column cover.
- Remove the four screws securing the rear dashboard to isolate the steering column. Then install the anti-rotation bracket (j) on the steering cylinder.  
**Caution:** The bracket must be fastened securely.



8. Install the previously assembled motor onto the steering column, ensuring that the anti-rotation pin fits into the anti-rotation bracket and that all screws are securely tightened. If any play or interference is detected, repeat all preceding steps.



9. Secure the motor to the steering column using the washer and nut you removed earlier. Make sure the nut is tightened securely. Then, apply the cap (●).



10. Plug the red and black terminals of the power cable (5.2.3) into the opening leading to the battery compartment on the right side of the tractor, where the telematics unit is located. Bring the cable terminals near the two battery terminals.

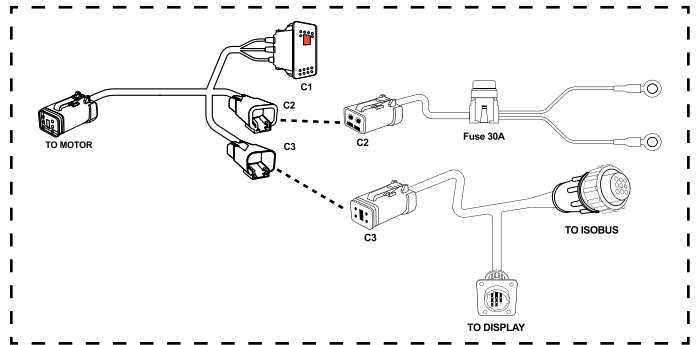

11. On the right-hand control panel, remove a cap and insert device cable (5.2.4) until the new electric motor on/off switch (C1) is secured.



12. Route the power cable and the motor cable (5.2.3 - 5.2.4) internally to the compartment above the battery. Then connect the C2 connectors on motor cable and power cable as well as the four-pin C3 connectors on motor cable and device cable.

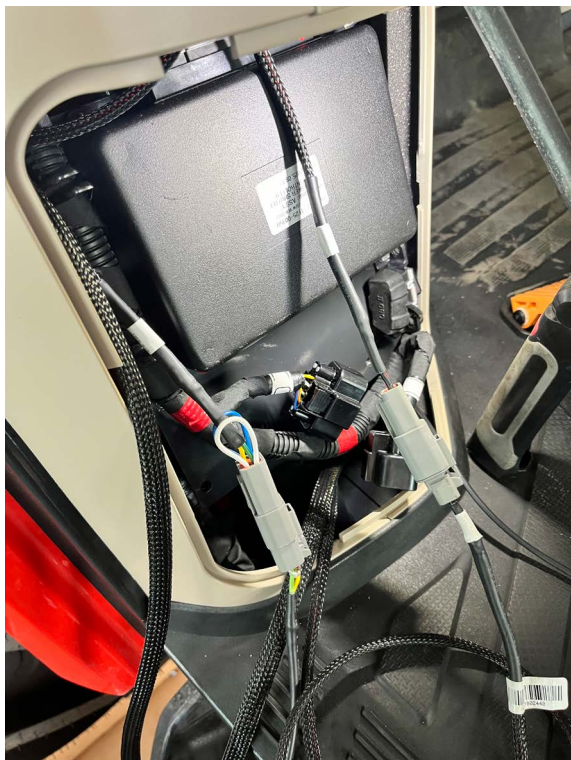

13. Connect the "TO ISOBUS" connector to the cab socket cable connector identified as [O]. Then connect the "TO DISPLAY" connector to the ISOBUS In-CAB cable.



14. Route the "TO MOTOR" (6-pin) toward the steering column. Lift the carpet on the front right side of the tractor and work your way down to the base of the steering column. Then route the cable internally until it is near the motor. Connect the connector to the motor without bending the wiring.

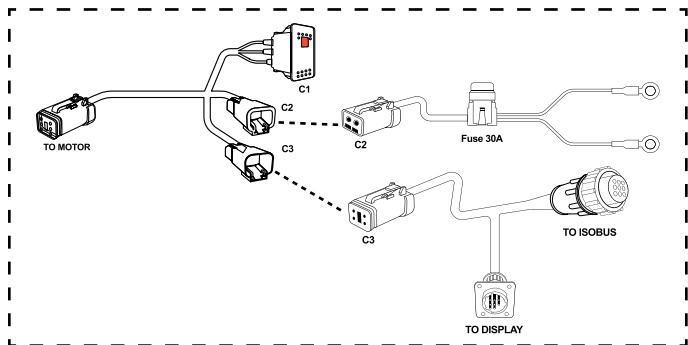

15. Once all panels and covers have been restored to their original position, connect all cables to the battery terminals and close the battery compartment.

The logo for FarmNavigator features the word "FARMNAVIGATOR" in a bold, green, sans-serif font. A stylized green leaf icon is positioned above the letter 'N'. Below the main text, the phrase "A BRAND BY AVMAP" is written in a smaller, grey, sans-serif font.

# FARMNAVIGATOR

A BRAND BY AVMAP

AvMap Srl  
Viale Zaccagna 6,  
54033 Carrara (MS), Italy

[kioti.support@farmnavigator.it](mailto:kioti.support@farmnavigator.it)